

PIA4800 SERIES

POWER SUPPLY CONTROLLER



Capable of controlling various power supplies and electronic loads.
 Supports multiple channels via a highly extensible slot-in system.
 Equipped with a high-speed serial communication function.

Outline

The PIA4810 is a power supply controller capable of analog and digital control. It is equipped with the GPIB and RS-232C interfaces and 4 slots, which allow 4 each of PIA4800 Series-specific control boards to be installed. A control board is capable of analog control of 2 channels of DC power supplies or electronic loads; a total of 8 channels can be controlled. Moreover, DC power supplies with a digital remote-control function, such as the Kikusui PMR Series, can be directly connected to the PIA4810 via a TP-BUS (twisted pair bus), enabling a maximum of 31 channels to be controlled digitally. PIA4820 is an expansion unit that can be connected to the PIA4810 or PIA4830 via a TP-BUS to provide additional control channels. In the same way as the PIA4810, it allows a maximum of 4 control boards to be installed. Then it is possible to use up to 3 units of PIA4820 as an expansion that can be connected to the PIA4810 via the TP-BUS, the system is capable of controlling a maximum of 32 channels. Moreover, the combined use of the GPIB and TP-BUS allows the system to control a maximum of 448 channels.

PIA4830 is a power supply controller only for digital control. It is capable of digitally controlling a maximum of 31 channels of Kikusui PMR Series DC power supplies via the TP-BUS. OP01-PIA and OP02-PIA are control boards designed exclusively for the PIA4810 and PIA4820. A single control board is capable of analog control of 2 channels of DC power supplies or electronic loads. The OP01-PIA is a full-control board with voltage and current setting and read-back functions, while the OP02-PIA4800 has only the voltage and current setting feature.

Features

- Extensible, flexible construction using the slot-in system (at the rear)
- Two types of control boards are available, and can be selected in accordance with user needs.
- The easy-to-connect TP-BUS is used for expansion. The total extension length of the TP-BUS is 200 m.

Line of the PIA4800 Series

Model	Product Name	Remarks
PIA4810	Power supply controller	Allows both analog and digital control
PIA4820	Expansion unit	Up to 3 units of PIA4820 can be connected to each PIA4810 or PIA4830.
PIA4830	Power supply controller	For Digital control only
OP01-PIA	Control board	Full control
OP02-PIA	Control board	Allows only Voltage and Current setting.

PIA4800 SERIES

POWER SUPPLY CONTROLLER

Description of Control

■ For OP01-PIA

Applied Series	PAK-A		PAD-L*7			PAN/PAN-A*7			PMC-A		PVS*7	
Connection Type	PAK-1	PAK-2	PAD-1	PAD-2	PAD-3	PAN-1	PAN-2	PAN-3	PMC-1	PMC-2	PVS-1	
Connection Method (Those marked with * are options.)	Flat cable accompanying OP01-PIA or optional flat cable SC01-10/20 *			Connector accompanying OP01-PIA (provided by the user)		Flat cable accompanying OP01-PIA or optional flat cable SC01-10/20 *		Connector accompanying OP01-PIA (provided by the user)		Optional 2-core twisted-pair cable SC03-PIA*		Connector accompanying OP01-PIA (provided by the user)
Peripheral options	SH		TU01+SH	TU01		TU02+SH	TU02		SH			
Output Voltage setting	✓	✓	✓	✓	✓	✓	✓	✓	✓	✓	✓	
Output Current setting	✓	✓	▲*5	▲*5	✓	✓	✓	✓	✓	✓	✓	
Output Voltage readback	✓	✓	✓	✓		✓	✓				✓	
Output Current readback	✓*1	✓*2	✓*1			✓*1			✓*1		✓	
Overvoltage protection setting	✓	✓										
Output ON/OFF	✓	✓	▲*5	▲*5		✓	✓					
POWER switch OFF	✓	✓	▲*3	▲*3								
Remote/Local switching	✓	✓										
Power switch OFF monitoring	✓	✓	▲*4,8	▲*4,8								
C.V mode monitoring	✓	✓	▲*4	▲*4		▲*4	▲*4					
C.C mode monitoring	✓	✓	▲*4	▲*4		▲*4	▲*4					
Output ON/OFF monitoring	✓	✓										
Overvoltage protection startup monitoring	✓	✓										
Overheat monitoring	✓	✓										
Alarm monitoring						▲*4	▲*4					

Applied Series	PAD-L	PAN/PAN-A	PMC-A	PVS	PLZ-WU*6	PLZ-W2*6
Connection	PAD-4	PAN-4	PMC-3	PVS-2	PLZ-WU	PLZ-W2
Connection Method	Twisted wire (provided by the user)		Option SC04-PIA	Twisted wire (provided by the user)		
Output voltage setting	✓	✓	✓	✓		
Output current setting	▲*5	✓	✓	✓	✓	✓
Output ON/OFF	▲*5	✓	✓		✓	

✓: controllable

No mark: not controllable

▲: controllable under certain conditions

*1: Linearity 0.3% of FS

*2: Linearity 1.5% of FS

*3: Types 0, I₁, and I₂ of the PAD-L series are uncontrollable.

*4: A DIN connector is required (Some types are not supported). (Available as factory option)

*5: Select between "Output current Settings" and "Output ON/OFF" (the Output ON/OFF function facilitates setting of the CV reference for types 0 and I₂, and setting of the CC reference for types other than those above, to 0).

*6: Using the electronic loads, read the output as a load value.

*7: OP01-PIA cannot control models with a rated output voltage exceeding 500 V.

*8: For types 0 and I₂ of the PAD-L series, rectifier circuit is monitored instead of POWER switch.

PIA4800 SERIES

POWER SUPPLY CONTROLLER

System Configuration

■ Example of connection 1

Power control system for 2 to 8 channels using one PIA4810

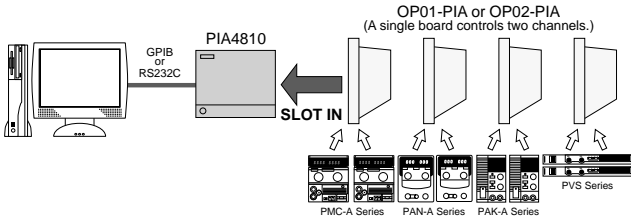

■ Example of connection 2

Power control system for 32 channels per one GPIB address using one PIA4810 and three PIA4820s

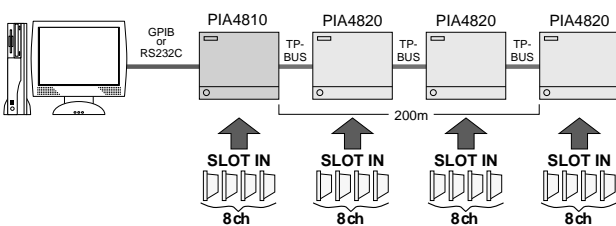

■ Example of connection 3

Power control system in which a power supply is directly connected to the system between two PIA 4820s (combination with power supply and power supply controllers)

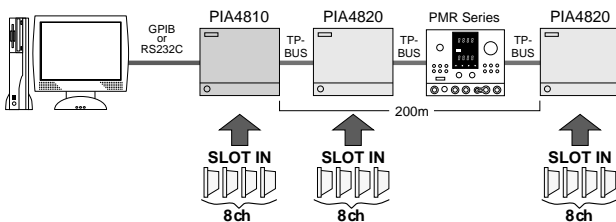

■ Example of connection 4

Power control system using one PIA4830 (controls up to of 31 channels)

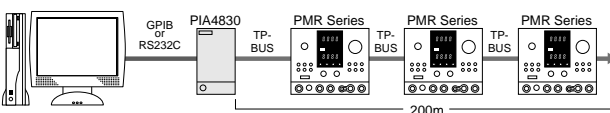

● Supplementary Note

- When the power control system in "Example connection 2" is provided as a basic configuration, the additional use of GPIB addresses allows it to control a maximum of 448 channels.
(32 channels x 14 addresses = 448 channels)
- The only models that can be directly connected for control to a power supply controller via a TP-BUS, as in "Example connection 3" or "4", are DC power supplies with a digital remote-control function.
- When the power control system in "Example connection 4" is provided as a basis, the additional use of GPIB addresses allows it to control a maximum of 434 channels.
(31 channels x 14 addresses = 434 channels)
It is also possible to construct a system with the same connections using the PIA4810.
- It is limited to use a TP-BUS for connecting up to 3 units of PIA4820. If you wish to connect more than three PIA4820s, please contact us.
- The total extension length of the TP-BUS for connection is up to 200 m.
- For advice on other connections, please contact us.

Application Examples

Knowledge of Microsoft Excel 97 Visual Basic is required.

PIA4800 Driver Objects

Installing PIA4800 Driver Objects contained in the PIA4800 Utilities CD supplied with the PIA4800 Series (PIA4810 or PIA4830) under Windows 95/98 allows a driver that can run when Microsoft Excel 97 is installed. Microsoft Excel 97 contains Excel 97 Visual Basic for the macro feature. The driver uses this feature to control the power supplies or electronic loads. Moreover, pasting data loaded from a power supply into Microsoft Excel 97 allows you to draw graphs of that data on the spot using the extensive graphing features of Excel 97.

● For Controlling Power Supplies or Electronic Loads

If you write a simple program using Excel 97 Visual Basic, simply entering voltage and current values and setting time in cells that allows you to control voltage and current as shown in the graph below.

The table and graph below show the results obtained when two power supplies were simultaneously tested using two loads.

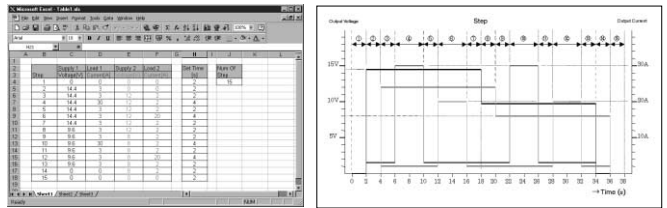

● Graphing Readout Data on the Spot

Using the readout function of the OP01-PIA and pasting data written in Excel 97 Visual Basic into cells in Microsoft Excel 97 allows that data to be graphed on the spot using the extensive graphing features of Excel 97.

The table and graph below show the results obtained when two power supplies were simultaneously tested using two loads.

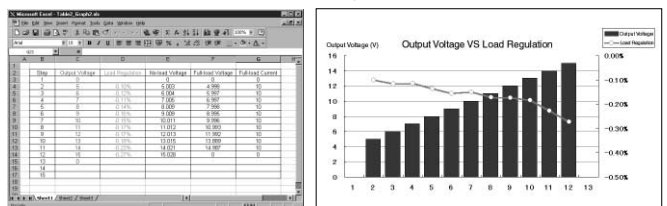

System Requirements of PIA4800 Driver Objects

- For users using GPIB
 - PC with Windows 95/98 or Windows NT4.0
 - National Instruments GPIB card with NI-488.2M software
 - GPIB cable
 - Microsoft Visual Basic 4.0 or later, or Microsoft Office 97 or later
 - For users using RS-232C
 - PC with Windows 95/98 or Windows NT4.0
 - One or more free RS-232C ports
 - RS-232C cross-cable
 - Microsoft Visual Basic 4.0 or later, or Microsoft Office 97 or later
- Notes
- Microsoft Windows, Microsoft Excel 97, and Microsoft Visual Basic are registered trademarks of Microsoft Corporation in USA.
 - When using the RS-232C interface, set the communications setting (baud rate) of the PIA4830 to 19,200 bps.
 - For Windows NT4.0, the Service Pack 3 or later version should be installed.

PIA4800 SERIES

POWER SUPPLY CONTROLLER

Connection Diagram [For OP01-PIA]

■ Example of connection PAK-A Series [PAK-1]

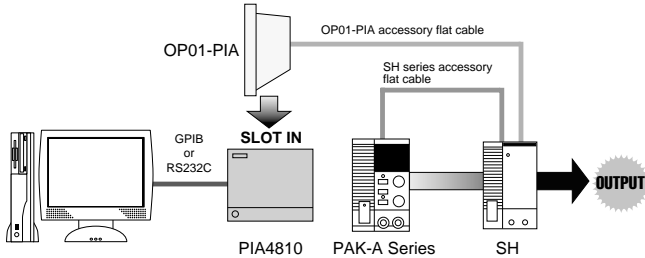

Note: The PAK-A series requires the IF01-PAK-A (factory-installed option).

■ Description of Control

● Output Voltage setting ● Output Current setting ● Output Voltage readback ● Output Current readback* ● Overvoltage protection setting ● Output ON/OFF ● POWER switch OFF ● Remote/Local switching ● Power switch OFF monitoring ● C.V mode monitoring ● C.C mode monitoring ● Output ON/OFF monitoring ● Overvoltage protection startup monitoring ● Overheat monitoring
*:Conditionally controllable (for details, see the table on page 5-3.)

■ Example of connection PAK-A Series [PAK-2]

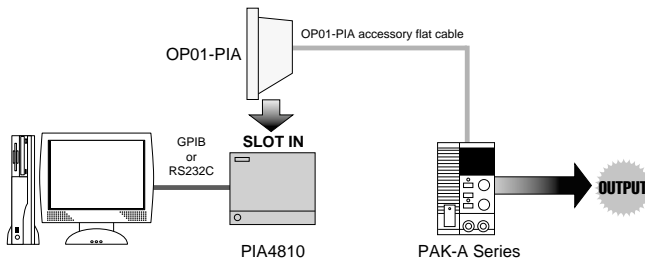

Note: The PAK-A series requires the IF01-PAK-A (factory-installed option).

■ Description of Control

● Output Voltage setting ● Output Current setting ● Output Voltage readback ● Output Current readback* ● Overvoltage protection setting ● Output ON/OFF ● POWER switch OFF ● Remote/Local switching ● Power switch OFF monitoring ● C.V mode monitoring ● C.C mode monitoring ● Output ON/OFF monitoring ● Overvoltage protection startup monitoring ● Overheat monitoring
*:Conditionally controllable (for details, see the table on page 5-3.)

■ Example of connection PAD-L Series [PAD-1]

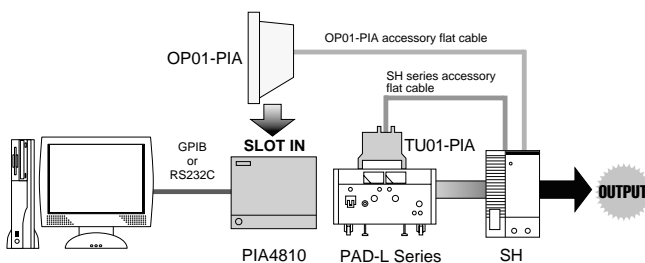

Note: The TU01-PIA is installed in the rear panel.

■ Description of Control

● Output Voltage setting ● Output Current setting* ● Output Voltage readback ● Output Current readback ● Output ON/OFF* ● POWER switch OFF* ● Power switch OFF monitoring* ● C.V mode monitoring* ● C.C mode monitoring*
*:Conditionally controllable (for details, see the table on page 5-3.)

■ Example of connection PAD-L Series [PAD-2]

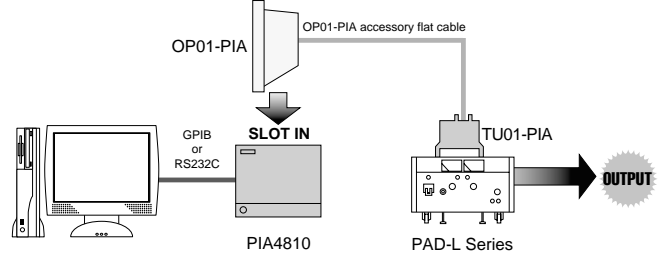

Note: The TU01-PIA is installed in the rear panel.

■ Description of Control

● Output Voltage setting ● Output Current setting* ● Output Voltage readback ● Output ON/OFF* ● POWER switch OFF* ● Power switch OFF monitoring* ● C.V mode monitoring* ● C.C mode monitoring*
*:Conditionally controllable (for details, see the table on page 5-3.)

■ Example of connection PAD-L Series [PAD-3]

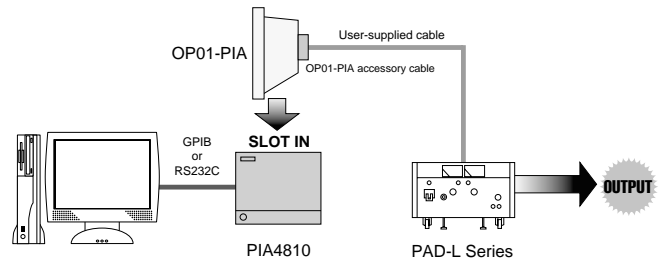

Note: To connect the power supply side of the user-supplied cable, fasten it with screws using crimp terminals.

■ Description of Control

● Output Voltage setting ● Output Current setting

■ Example of connection PAN-A Series [PAN-1]

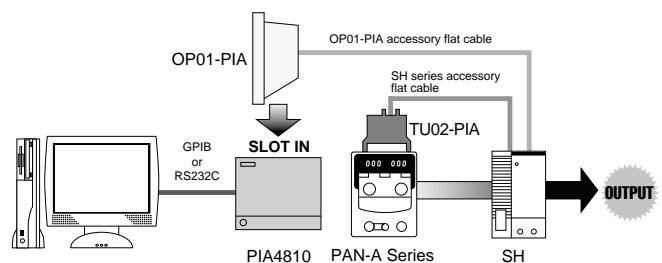

Note: The TU02-PIA is installed in the rear panel.

■ Description of Control

● Output Voltage setting ● Output Current setting ● Output Voltage readback ● Output Current readback ● Output ON/OFF ● C.V mode monitoring* ● C.C mode monitoring* ● Alarm monitoring*
*:Conditionally controllable (for details, see the table on page 5-3.)

PIA4800 SERIES

POWER SUPPLY CONTROLLER

Connection Diagram [For OP01-PIA]

■ Example of connection PAN-A Series [PAN-2]

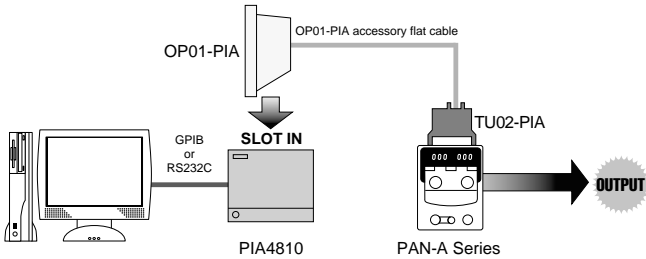

Note: The TU01-PIA is installed in the rear panel.

■ Description of Control

- Output Voltage setting ● Output Current setting ● Output Voltage readback
- Output Current readback ● Output ON/OFF ● C.V mode monitoring* ● C.C mode monitoring* ● Alarm monitoring*

*:Conditionally controllable (for details, see the table on page 5-3.)

■ Example of connection PAN-A Series [PAN-3]

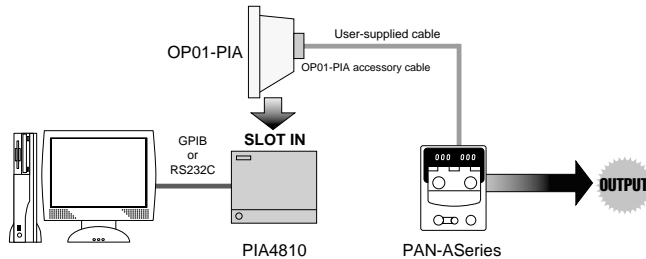

Note: To connect of the power supply side of the user-supplied cable, remove the covering from the wires and insert them into the terminals.

■ Description of Control

- Output Voltage setting ● Output Current setting

■ Example of connection PMC-A Series [PMC-1]

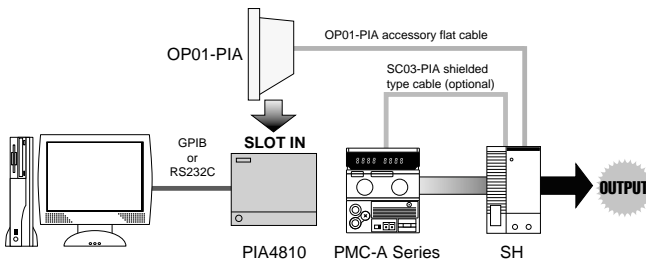

■ Description of Control

- Output Voltage setting ● Output Current setting ● Output Current readback

■ Example of connection PMC-A Series [PMC-2]

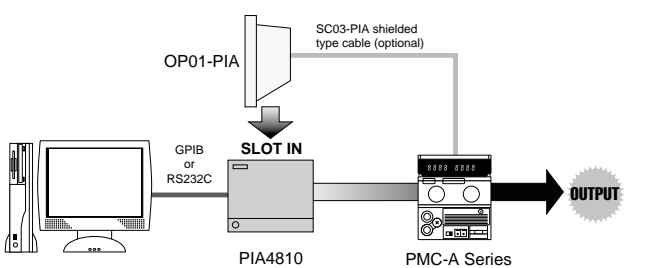

■ Description of Control

- Output Voltage setting ● Output Current setting

Connection Diagram [For OP02-PIA]

■ Example of connection PVS Series [PVS-1]

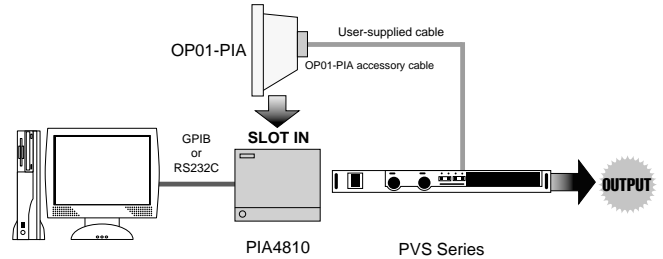

■ Description of Control

- Output Voltage setting ● Output Current setting ● Output Voltage readback
- Output Current readback

■ Example of connection PMC-A Series [PMC-3]

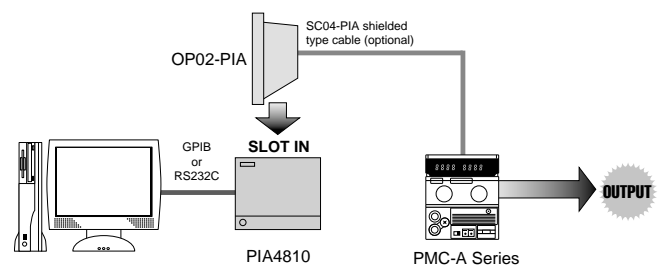

■ Description of Control

- Output Voltage setting ● Output Current setting ● Output ON/OFF

■ Example of connection PAD-L Series [PAD-4], PAN-A Series [PAN-4], PVS Series [PVS-2], PLZ-WU, PLZ-W2

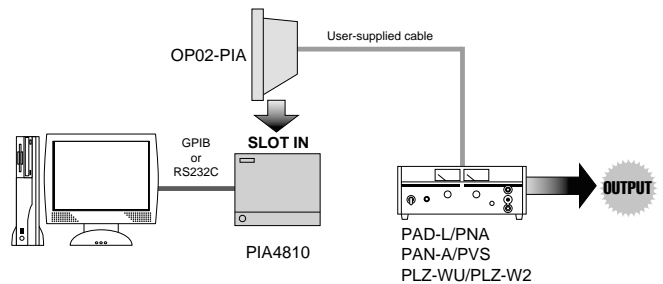

■ Description of Control

PAD-L Series [PAD-4]

- Output Voltage setting ● Output Current setting* ● Output ON/OFF*

PAN-A Series [PAN-4]

- Output Voltage setting ● Output Current setting ● Output ON/OFF

PVS Series [PVS-2]

- Output Voltage setting ● Output Current setting

PLZ-WU

- Output Current setting ● Output ON/OFF

PLZ-W2

- Output Current setting

*:Conditionally controllable (for details, see the table on page 5-3.)

PIA4800 SERIES

POWER SUPPLY CONTROLLER

Specifications (Main Unit)

Item		Specifications		
		PIA4810	PIA4820	PIA4830
TU-BUS	Connection	Using the accompanying TP-BUS connector, connect the following: DC power supply unit with digital remote - control function: Up to 31 units Expansion unit PIA4820: Up to three units (Total cable length: Up to 200 m; Number of twists: 1 or more/cm)		
	Polarity	None		
	Applicable cable	Twisted wire: 0.32 mm ² (AWG22)		
SHUT	Input signal	The output of all connected DC DOWN supply units is turned off when a contact signal is input for at least 1 second.	/	The output of all connected DC power- when a contact signal is input for at least 1 second.
	+ terminal	Pull up to +5 V with 4.7 kΩ		Pull up to +5 V with 4.7 kΩ
	- terminal	Common for control block		Common for control block
	Applicable cable	Single wire: φ0.65 (AWG22) Twisted wire: 0.32 mm ² (AWG22) Element wire diameter: of at least φ0.18		Single wire: φ0.65 (AWG22) Twisted wire: 0.32 mm ² (AWG22) Element wire diameter: of at least φ0.18
Input	Voltage range	The following ranges can be selected using the voltage switch on the bottom of the unit. 90 VAC to 110 VAC / 106 VAC to 125 VAC / 180 VAC to 220 VAC / 211 VAC to 250 VAC		85 VAC to 250 VAC
	Frequency	48Hz to 62Hz		
	Power consumption	Up to 50VA		
Operating ambient temperature and humidity		0°C to 40°C, 10% to 90% (No dew condensation)		
Storage ambient temperature and humidity		-20°C to 70°C, 10% to 90% (No dew condensation)		
Insulation resistance	Input - chassis	500 VDC, 30MΩ or more		
	TP-BUS - chassis	1000 VDC, 30MΩ or more		
	CH terminals - chassis	500 VDC, 30MΩ or more		
Withstand voltage	Input - chassis	1500 V AC, 1 minute		
	Input - TP-BUS	1500 V AC, 1 minute		
	TP-BUS - chassis	600 V AC, 1 minute		
	CH terminals - chassis	600 V AC, 1 minute		
	Input - CH terminals	1500 V AC, 1 minute		
Weight	Approx. 5 kg		Approx. 2 kg	
Dimensions	141.9 W X 123.4 (160) H X 350 (365) Dmm		70.4 W X 123.4 (150) H X 350 (365) Dmm	
Accessories	AC power cord: 1 PIA4800 Utilities CD: 1 DOS IBM-PC/AT FD: 1 DOS PC9801 FD: 1 TP-BUS connector: 1 TP-BUS core: 1 Operation Manual for controller: 1 PIA4800 Driver Objects Programming Guide: 1	AC power cord: 1 DOS IBM-PC/AT FD: 1 DOS PC9801 FD: 1 TP-BUS connector: 1 TP-BUS core: 1 Operation Manual for controller: 1	AC power cord: 1 PIA4800 Utilities CD: 1 TP-BUS connector: 1 TP-BUS core: 1 Operation Manual for controller: 1 PIA4800 Driver Objects Programming Guide: 1	

Rear Panel

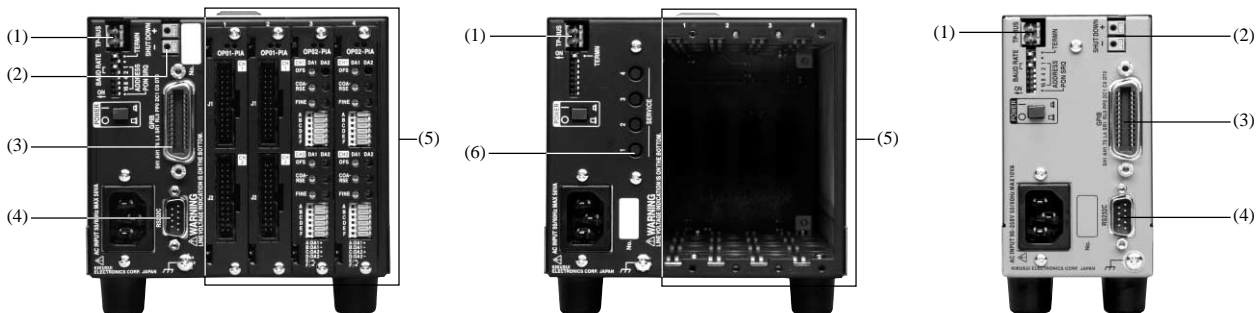

- (1) TP-BUS (special bus)
- (2) SHUT DOWN
Turns off the outputs of connected power supplies using contact input.
- (3) GPIB
- (4) RS232C
- (5) Control board slots 1 to 4
Used to insert control boards OP01-PIA and OP02-PIA. Up to 4 control boards can be installed (combined use of the 2 types is possible).
* The photo shows the controller with 4 control boards (options) installed.
- (6) SERVICE
Used to specify the node addresses of installed control boards according to software instructions when GPIB control is performed.

PIA4800 SERIES

POWER SUPPLY CONTROLLER

Specifications (Control Boards)

Item			OP01-PIA	OP02-PIA
Number of channels			2	2
Setting	Voltage setting	Output	0 to +10V	0 to +10V
		Resolution	0.025% of FS	0.025% of FS
		Linearity*1	0.013% of FS	0.013% of FS
		Temperature coefficient*2	50ppm/°C of FS	50ppm/°C of FS
	Current setting	Output (H)	0 to +10V	0 to +10V
		Output (M)	0 to +1.5V	0 to +1.5V
		Output (L)	0 to +0.4V	0 to +0.4V
		Resolution	0.025% of FS	0.025% of FS
		Linearity*1	0.025% of FS	0.025% of FS
		Temperature coefficient*2	100ppm/°C of FS	100ppm/°C of FS
Read-back	Voltage read-back	Input	0 to +10V	OP02-PIA has no read back function
		Resolution	0.025% of FS	
		Linearity*1	0.025% of FS	
		Temperature coefficient*2	100ppm/°C of FS	
	Current read-back	Input (H)	0 to +10V	
		Input (L)	0 to +1V	
		Resolution	0.025% of FS	
		Linearity*1	0.025% of FS	
		Temperature coefficient*2	100ppm/°C of FS	

FS is at the rated voltage or current.

*1: After 30 minutes of warm-up at of 23 ±5°C and 80% R.H or less.

*2: Indicates the standard value.

Options

- Interface card
(Factory option)
IF01-PAK-A (PAK-A compatible)
- Shunt units
SH-10 (output current rating: 2.5 A to 10 A)
SH-50 (output current rating: 12.5 A to 50 A)
- Terminal units
TU01-PIA (PAD-L/LP compatible)
TU02-PIA (PAN-A compatible)
- Shielded 26-conductor flat cables
(OP01-PIA, PAD-L/LP, PAK-A, and PAN-A compatible)
SC01-10 (about 1.0 m)
SC01-20 (about 2.0 m)
- Shielded two-conductor twisted pair cables
SC03-PIA (OP01-PIA and PMC-A compatible, about 1.0 m)
SC04-PIA (OP02-PIA and PMC-A compatible, about 1.0 m)
- GPIB cables
(ready for use with all models)
408J-101 (about 1.0 m)
408J-102 (about 2.0 m)
408J-104 (about 4.0 m)

Rack Mount Options & Dimensions(mm)

PIA4810/PIA4820

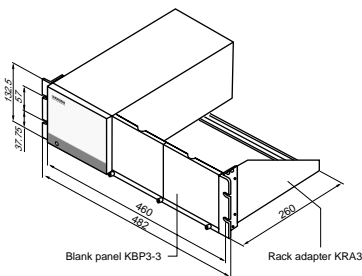

(Inch size, EIA standard)

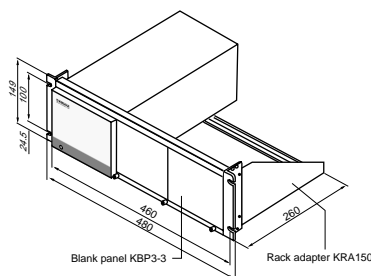

(mm size, JIS standard)

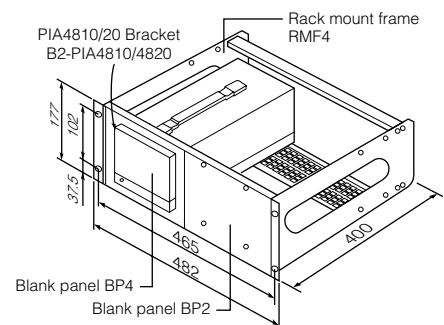

PIA4830

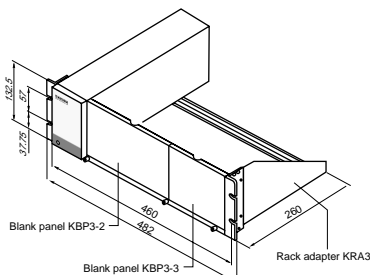

(Inch size, EIA standard)

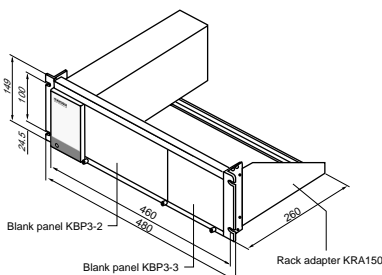

(mm size, JIS standard)

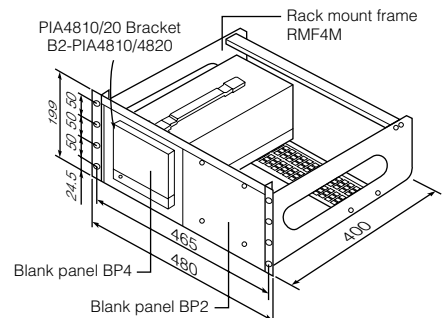

* When mounting the PIA4800 Series in racks, the specified space are required to be provided above and below the instruments. (Specified space: 44.45 mm in EIA standard or 50 mm in JIS standard)

For more information, contact your Kikusui agent.

* Only PIA4810 and PIA4820 can be equipped with RMF4 or RMF4M, PIA4830 can be equipped with KRA3 or KRA150.