

TOS6210

Ground Bond Tester

Ground Bond tester supporting standard compliance tests up to 60A



TOS6210



Test up to 60A is possible!

While inheriting the basic performance and functions of its predecessor (TOS6200), such as a constant current driving system that provides current waveforms with little skew and high measurement accuracy, the TOS6210 tester extends the maximum test current from 30 A to 60 A, which is demanded by the new standard.

In addition, the tester also lets you judge the acceptability of the device under test based on the drop in voltage, as required in the standard. What's more, you can preset test conditions of up to 20 different types of safety standards, such as those for information technology equipment, home appliances, medical devices, and measuring instruments, in the memory on the main unit's panel.

A simple memory call operation allows you to set up a protective earth or protective bonding continuity test as stipulated in UL60950-1 and other relevant specifications including IEC and JIS standards.

The tester also features a set of functions that meet the specific needs of testing personnel, such as an offset cancellation function and a memo function that allows you to input calibration dates, production numbers, and other test-related information and read the input information later via the GPIB or RS-232C interface.

- Test current value: 6 to 60 A AC / Resistance value: 0.001 to 0.600Ω
- Voltage drop-based judgment function
- Offset cancelling function
- Stores 100 test conditions in memory
- Incorporates test conditions into program
- Contact check function
- Equipped with standard GPIB and RS-232C interfaces
- Equipped with standard test lead (TL12-TOS)

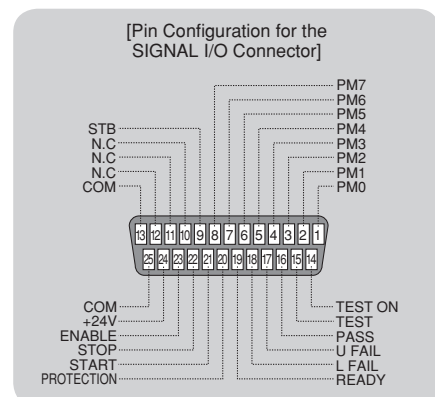

TOS6210

Ground Bond Tester

Output block		
Current setting range (*1)	6.0 to 62.0 A AC (With respect to resistance resulting in output power of the maximum rated Output or less and an output terminal voltage of 5.4 V or less)	
Resolution	0.1A	
Accuracy	± (1% of setting + 0.4A)	
Maximum rated output	220 VA (at the output terminals)	
Distortion factor	2% or less (with respect to 0.1 Ω pure resistance load of 20 A or greater)	
Frequency	50/60 Hz, sine wave (selectable)	
Accuracy	±200ppm	
Open terminal voltage	6 Vrms or less	
Output method	PWM switching method	
Output ammeter		
Measurement range	0.0 to 66.0 A AC	
Resolution	0.1A	
Accuracy	± (1% of reading + 0.4A)	
Response	Mean value response/rms value display (response time: 200 ms)	
Holding function	The current measured at the end of test is held during the PASS or FAIL interval	
Output voltmeter		
Measurement range	0.00 to 6.00 V AC	
Resolution	0.01V	
Offset cancel function	0.00 to 5.40 V (Offset ON/OFF function provided)	
Accuracy	± (1% of reading + 0.02V)	
Response	Mean value response/rms value display (response time: 200 ms)	
Holding function	The voltage measured at the end of test is held during the PASS or FAIL interval	
Ohmmeter (*2)		
Measurement range	0.001 to 0.600 Ω	
Resolution	0.001 Ω	
Offset cancel function	0.000 to 0.600 Ω (Offset ON/OFF function provided)	
Accuracy	± (2% of reading + 0.003 Ω)	
Holding function	The resistance measured at the end of test is held during the PASS or FAIL interval	
Pass/fail judgement function (*3)		
Resistance value-based judgement	Window comparator system <ul style="list-style-type: none"> •If a resistance value equal to or greater than the upper reference value is detected, a FAIL determination is returned. •If a resistance value equal to or less than the lower reference value is detected, a FAIL determination is returned. •If a resistance value has been judged as FAIL, the tester shuts off the output and generates a FAIL signal. •If the set time elapses without abnormalities, the tester shuts off the output and generates a PASS signal. 	
Setting range for the upper reference value (UPPER)	0.001 to 0.600 Ω	
Setting range for the lower reference value (LOWER)	0.001 to 0.600 Ω	
Resolution	0.001 Ω	
Judgement accuracy	± (2% of UPPER + 0.003 Ω)	
Sampled voltage value-based judgement	Window comparator system <ul style="list-style-type: none"> •If a voltage value equal to or greater than the upper reference value is detected, a FAIL determination is returned. •If a voltage value equal to or less than the lower reference value is detected, a FAIL determination is returned. •If a voltage value has been judged as FAIL, the tester shuts off the output and generates a FAIL signal. •If the set time elapses without abnormalities, the tester shuts off the output and generates a PASS signal. 	
Setting range for the upper reference value (UPPER)(*4)	0.01 to 5.40 V	
Setting range for the lower reference value (LOWER)	0.01 to 5.40 V	
Resolution	0.01 V	
Judgement accuracy	± (2% of UPPER + 0.05 V)	
Calibration		
Calibration is performed with the rms value of the sine wave, using a pure resistance load.		
LED	PASS	Lights for approximately 0.2 sec when the measured value has been judged as PASS. It is lit continuously when the PASS holding time is set to HOLD.
	UPPER FAIL	Lights if a resistance or voltage value equal to or greater than the upper reference value is detected and judged FAIL.
	LOWER FAIL	Lights if a resistance or voltage value equal to or greater than the upper reference value is detected and judged FAIL.
Buzzer	<ul style="list-style-type: none"> •The buzzer sounds for the pass holding time has been set if the measured value has been judged as PASS. •The buzzer sounds continuously under the following condition: The measured value has been judged as PASS when the PASS holding time is set to HOLD. The measured value has been judged as UPPER FAIL. The measured value has been judged as LOWER FAIL. •The buzzer volume for FAIL or PASS judgment are adjustable. <p>Note that it cannot be adjusted individually since setting is shared with the setting for PASS.</p>	

*1: Time limitation with respect to output

The heat radiation capacity at the output block of the tester is designed to be one-third of the rated output, accounting for size, weight, cost, and other factors. Always use the tester within the limitation values given below. Use of the tester beyond these limits will cause the temperature of the output block to rise excessively, potentially tripping the internal protection circuit. In this case, suspend testing for approximately 30 minutes, then press the STOP switch. When temperatures fall to normal levels, the tester will revert to ready status.

Output time limitation			
Ambient temperature t (°C)	Test current I (A)	Pause time	Maximum allowable continuous test time
t ≤ 40°	40 < I ≤ 60	Equal to or greater than the test time	≤ 10 minutes
	20 < I ≤ 40	Equal to or greater than the test time	≤ 30 minutes
	I ≤ 20	Not required	Continuous output possible

*2: About ohmmeter's response time

A resistance value is instantaneously obtained, calculated using the measured voltage and current values. The response time of the ohmmeter complies with the response times of the voltmeter and ammeter.

*3: Resistance value-based and sampled voltage value-based judgments cannot be simultaneously conducted.

*4: Limited by the maximum rated output and the output terminal voltage.

The tester can be used within the range shown below.

Allowable range in which to determine the test current value and upper reference value

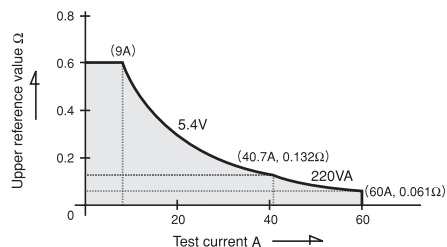

TOS6210

Ground Bond Tester

Time		
Test time	Setting range	0.3 to 999 s Timer ON/OFF function is available.
	Accuracy	± (100ppm of setting + 20ms)
Environment		
Operating environment		Indoor use, Overvoltage Category II
Warranty range	Temperature	5° to 35°C
	Humidity	20 %rh to 80 %rh (non condensing)
Operating range	Temperature	0° to 40°C
	Humidity	20 %rh to 80 %rh (non condensing)
Storage range	Temperature	-20° to 70°C
	Humidity	90 %rh or less (non condensing)
Altitude		Up to 2000m
Power requirement		
Allowable voltage range		85 to 250 V AC
Power consumption	At no load (READY)	60 VA or less
	At rated load	420 VA max.
Allowable frequency range		47 Hz to 63 Hz
Insulation resistance		30MΩ min. (500 V DC), between AC line and chassis
Hipot		1390 V AC (2 seconds), between AC line and chassis
Ground bond		25 A AC/0.1 Ω max.
Electromagnetic compatibility (EMC) (*5,6)		
Conforms to the requirements of the following directive and standard.		
EMC Directive 89/336/EEC		
EN61326		
EN61000-3-2		
EN61000-3-3		
Under following conditions		
1. Used test leadwire (TL12-TOS) which is supplied.		
2. Used the shielded cable which length is less than three meters when the SIGNAL I/O is used.		
Safety (*5)		
Conforms to the requirements of the following directive and standard.		
Low Voltage Directive 73/23/EEC		
EN61010-1		
Class I		
Pollution degree 2		
Physical dimensions (max)		430(455)W × 88(140)H × 270(350)Dmm
Weight		Approx. 11kg
Accessories		
AC power cord		1 piece
Test leadwire TL12-TOS		1 set
Short bar		2 pieces (These are inserted between the OUTPUT and SAMPLING terminals.)
AC power fuse		2 pieces (2, including one spare in the fuse holder)
Operation manual		1 copy

*5: Not applicable to custom order models.

*6: Only on models that have CE marking on the panel.

External dimensional diagrams

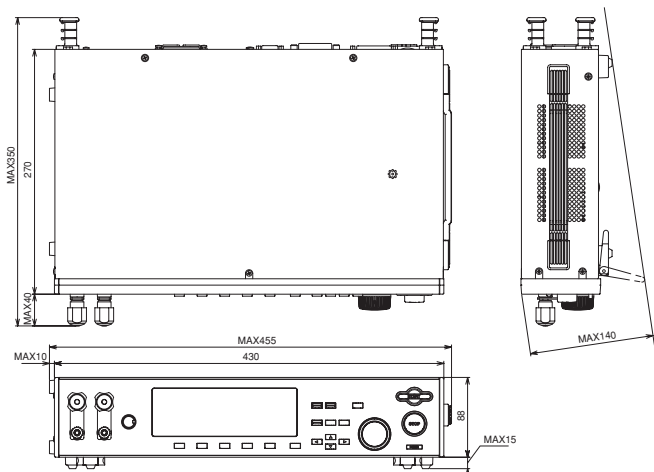

Unit: mm



KIKUSUI ELECTRONICS CORPORATION

1-1-3, Higashiyamata, Tsuzuki-ku, Yokohama, 224-0023, Japan
Phone: (+81) 45-593-7570, Facsimile: (+81) 45-593-7571, www.kikusui.co.jp

KIKUSUI AMERICA, INC. Toll Free **1-800-KIKUSUI** www.kikusui.us



1744 Rollins Road, Burlingame, CA 94010
Phone : 650-259-5900 Facsimile : 650-259-5904

KIKUSUI TRADING (SHANGHAI) Co., Ltd. www.kikusui.cn



Room, D-01,11F, Majesty Bld, No.138, Pudong Ave, Shanghai City
Phone : 021-5887-9067 Facsimile : 021-5887-9069

For our local sales distributors and representatives, please refer to "sales network" of our website.

Recycled Paper

●Distributor:

■ All products contained in this catalogue are equipment and devices that are premised on use under the supervision of qualified personnel, and are not designed or produced for home-use or use by general consumers. ■ Specifications, design and so forth are subject to change without prior notice to improve the quality. ■ Product names and prices are subject to change and production may be discontinued when necessary. ■ Product names, company names and brand names contained in this catalogue represent the respective registered trade name or trade mark. ■ Colors, textures and so forth of photographs shown in this catalogue may differ from actual products due to a limited fidelity in printing. ■ Although every effort has been made to provide the information as accurate as possible for this catalogue, certain details have unavoidably been omitted due to limitations in space. ■ If you find any misprints or errors in this catalogue, it would be appreciated if you would inform us. ■ Please contact our distributors to confirm specifications, price, accessories or anything that may be unclear when placing an order or concluding a purchasing agreement.

Printed in Japan

Issue:Feb.2008

2008021KCMEC41